



SNAP-TOP®

STANDOFFS

BULLETIN



SSA 505

Revised 406

PEM® SNAP-TOP STANDOFFS

PEM SNAP-TOP® Standoffs (Types SSA, SSS, SSC, KSSB) are designed for permanent installation into metal panels or PC boards.

These all-metal standoffs use a spring action to hold PC boards and subassemblies securely, while allowing for quick removal. Screws and other threaded hardware are eliminated. This means less parts to handle during assembly and less risk of damaging delicate circuitry because of loose parts falling into your equipment.

These standoffs are permanently installed in the panel by squeezing them into a punched or drilled hole using any standard press. Installation forces, pushout, and snap forces, are listed on page 6.

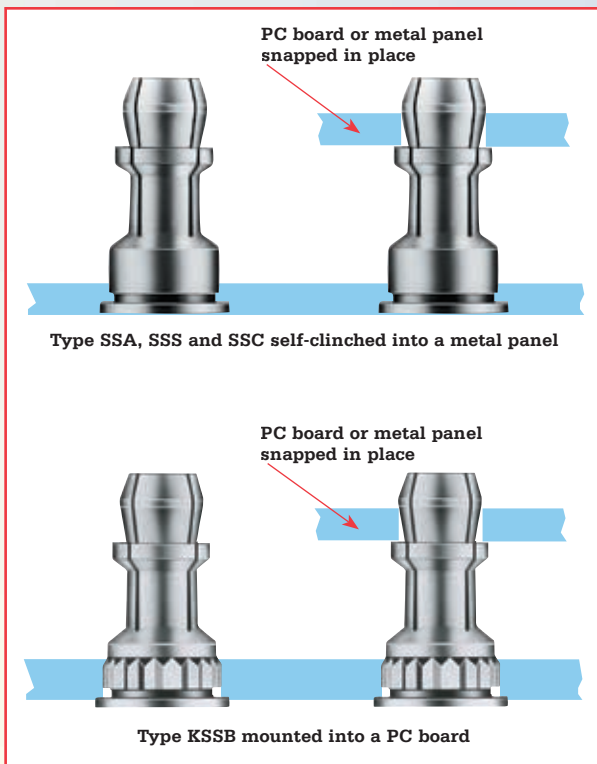

SSA, SSS, SSC



KSSB



TYPES SSA™, SSS™, SSC™ FOR CLINCHING INTO METAL SHEETS

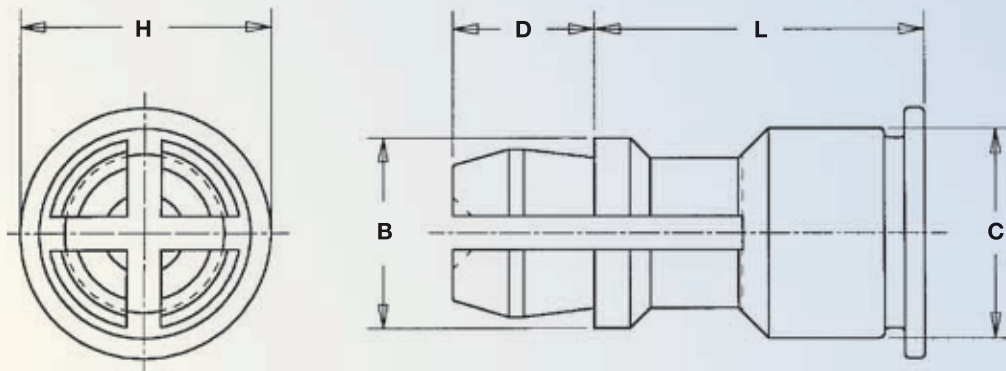

Part Number Designation

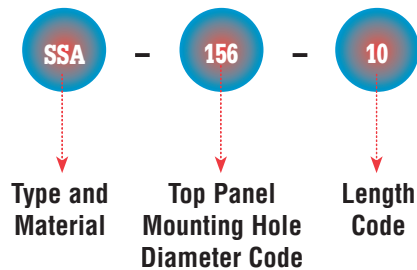

FASTENER MATERIAL:

Type SSA – 7075-T6 Aluminum
 Type SSS – Carbon Steel
 Type SSC – 400 Series Stainless Steel

FINISH:

Type SSA – Plain Finish
 Type SSS – Zinc plus clear chromate per ASTM B633, SC1 (5µm), Type III, colorless
 Type SSC – Passivated and/or tested per ASTM A380

Dimensional Data

All dimensions are in inches.

UNIFIED	Type			Top Panel Mounting Hole Diameter Code	Length Code "L" ±.005 (Length Code in 32nds of an inch)										B ±.005	C Max.	D ±.005	H ±.005
	Fastener Material																	
	Aluminum	Carbon Steel	Stainless Steel															
SSA	SSS	SSC	156	.250	.312	.375	.437	.500	.562	.625	.750	.875	1.00	.188	.212	.141	.250	
				8	10	12	14	16	18	20	24	28	32					

All dimensions are in millimeters.

METRIC	Type			Top Panel Mounting Hole Diameter Code	Length Code "L" ±0.13 (Length Code in millimeters)										B ±0.13	C Max.	D ±0.13	H ±0.13
	Fastener Material																	
	Aluminum	Carbon Steel	Stainless Steel															
SSA	SSS	SSC	4mm	8	10	12	14	16	18	20	22	25	4.78	5.39	3.58	6.35		

TYPE KSSB™ FOR BROACHING INTO PC BOARDS

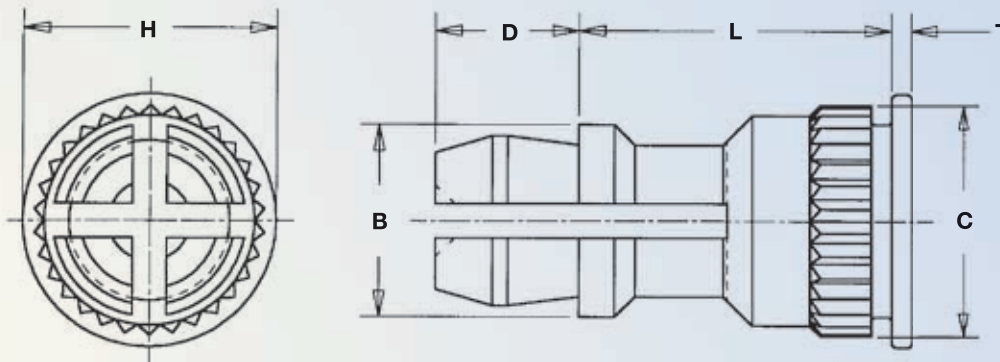

Part Number Designation

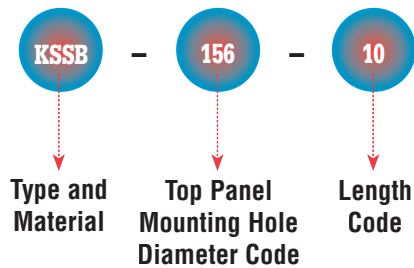

FASTENER MATERIAL:

Free Machining Brass

FINISH:

Standard – Plain

Optional* – Electroplated Bright Tin,
ASTM B545 Class B (5µm)
with preservative coating

**Available on special order with additional charge.*

Dimensional Data

All dimensions are in inches.

UNIFIED	Type	Top Panel Mounting Hole Diameter Code	Length Code "L" ±.005 (Length Code in 32nds of an inch)										B ±.005	C ±.003	D ±.005	H ±.005	T ±.005
			.250	.312	.375	.437	.500	.562	.625	.750	.875	1.00					
KSSB	156		.250	.312	.375	.437	.500	.562	.625	.750	.875	1.00	.188	.226	.141	.250	.020
			8	10	12	14	16	18	20	24	28	32					

All dimensions are in millimeters.

METRIC	Type	Top Panel Mounting Hole Diameter Code	Length Code "L" ±0.13 (Length Code in millimeters)										B ±0.13	C ±0.08	D ±0.13	H ±0.13	T ±0.13
			8	10	12	14	16	18	20	22	25						
KSSB	4mm		8	10	12	14	16	18	20	22	25	4.78	5.74	3.58	6.35	0.51	

APPLICATION DATA - TYPES SSA, SSS, SSC

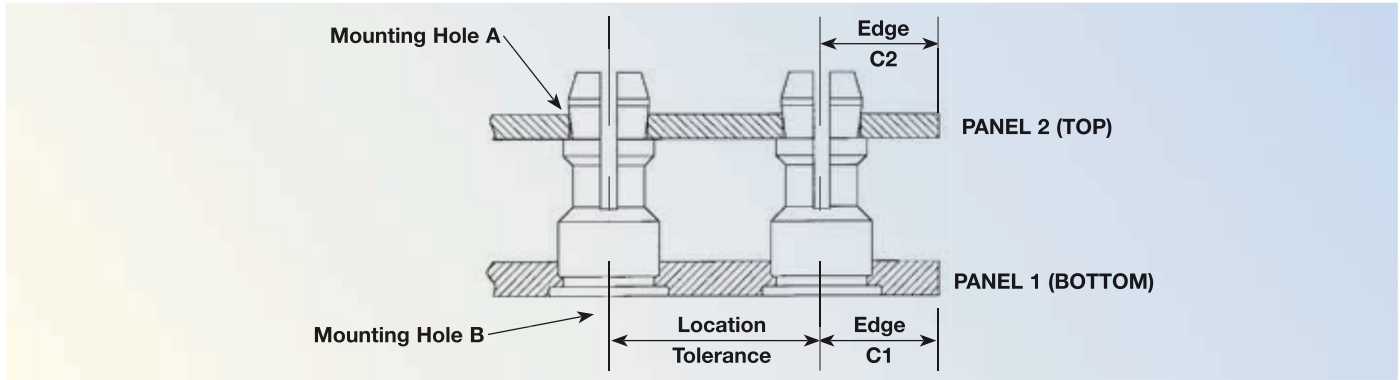

All dimensions are in inches.

UNIFIED	Type	Panel 1					Panel 2					
		Bottom Mounting Hole B +.003 -.000	Panel Material	Hardness Max. (1)	Thickness Min.	Edge Distance C ₁ Min.	Location Tolerance Max.	Top Mounting Hole A +.003 -.000	Panel Material	Hardness Max.	Thickness Range (2)	Edge Distance C ₂ Min.
	SSA	.213	Metal ⁽¹⁾	HRB 50	.040	.260	±.005	.156	PC Board or Metal	No Limit	.040-.070	.100
	SSS			HRB 60								
	SSC			HRB 70								

All dimensions are in millimeters.

METRIC	Type	Panel 1					Panel 2					
		Bottom Mounting Hole B +0.08	Panel Material	Hardness Max. (1)	Thickness Min.	Edge Distance C ₁ Min.	Location Tolerance Max.	Top Mounting Hole A +0.08	Panel Material	Hardness Max.	Thickness Range (2)	Edge Distance C ₂ Min.
	SSA	5.41	Metal ⁽¹⁾	HRB 50	1	6.6	±0.13	4	PC Board or Metal	No Limit	1-1.8	2.54
	SSS			HRB 60								
	SSC			HRB 70								

APPLICATION DATA - TYPE KSSB

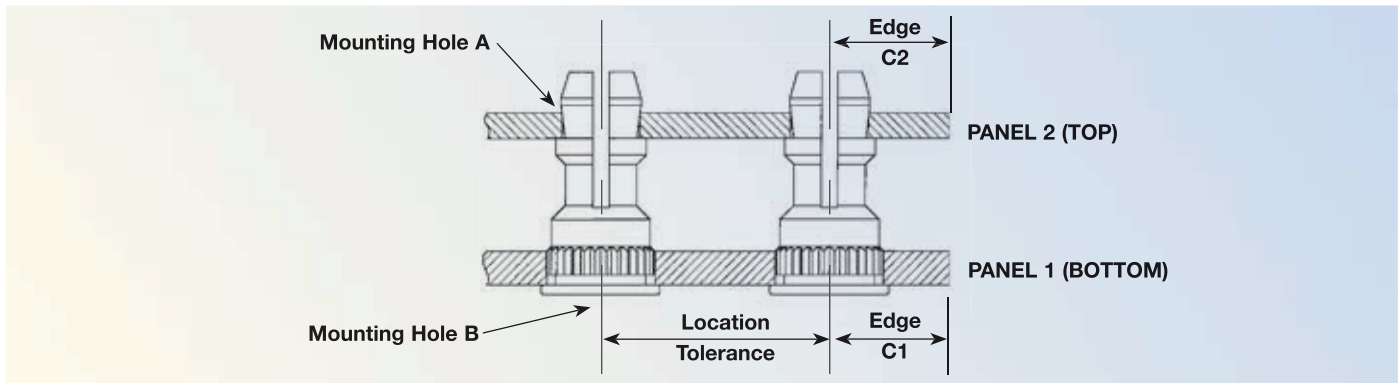

All dimensions are in inches.

UNIFIED	Type	Panel 1					Panel 2					
		Bottom Mounting Hole B +.003 -.000	Panel Material	Hardness Max.	Thickness Min.	Edge Distance C ₁ Min.	Location Tolerance Max.	Top Mounting Hole A +.003 -.000	Panel Material	Hardness Max.	Thickness Range (2)	Edge Distance C ₂ Min.
	KSSB	.213	PC Board	HRB 65	.050	.220	±.005	.156	PC Board or Metal	No Limit	.040-.070	.100

All dimensions are in millimeters.

METRIC	Type	Panel 1					Panel 2					
		Bottom Mounting Hole B +0.08	Panel Material	Hardness Max.	Thickness Min.	Edge Distance C ₁ Min.	Location Tolerance Max.	Top Mounting Hole A +0.08	Panel Material	Hardness Max.	Thickness Range (2)	Edge Distance C ₂ Min.
	KSSB	5.41	PC Board	HRB 65	1.27	5.59	±0.13	4	PC Board or Metal	No Limit	1-1.8	2.54

(1) Type SSA standoffs are self-clinching in cold-rolled steel provided hardness is less than HRB 50. (2) Available for thicker boards on special order.

INSTALLATION

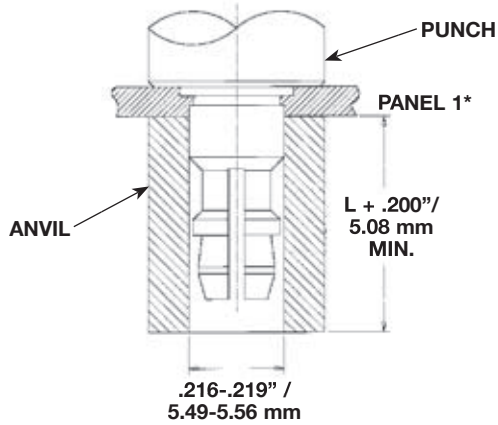

Types SSA, SSS, SSC

- 1.** Punch or drill the properly sized mounting hole in the panel.
- 2.** Place the fastener through the mounting hole of the panel and into the anvil as shown in the drawing.
- 3.** With punch and anvil surfaces parallel, apply only enough squeezing force to embed the head flush with the panel.

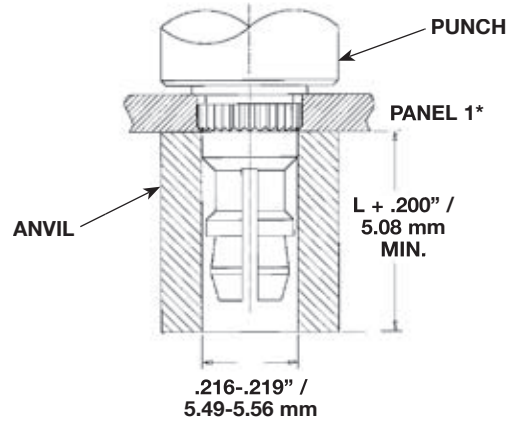

Type KSSB

- 1.** Punch or drill the properly sized mounting hole in the board.
- 2.** Place the fastener through the mounting hole of the board and into the anvil as shown in the drawing.
- 3.** With punch and anvil surfaces parallel, apply only enough squeezing force to bring the head into contact with the board.

*See drawing below for reference.

PERFORMANCE DATA⁽¹⁾

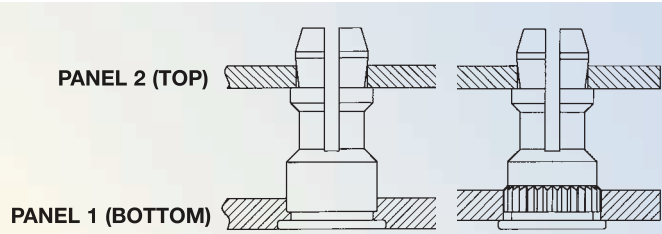

UNIFIED	Panel 1				Panel 2 (Removable)		
	Type	Test Sheet Material	Installation (lbs.)	Pushout (lbs.)	Max. First on Snap Force (lbs.)	Min. First off Snap Force (lbs.)	Min. 15th off Snap Force (lbs.)
	SSA	Aluminum	1500	200	13	3	1
	SSS	Aluminum	1500	200	20	6	2
	SSS	Cold-rolled Steel	3500	400	20	6	2
	SSC	Cold-rolled Steel	3600	400	20	6	2
	KSSB	FR-4 Fiberglass	500	110	13	3	1

METRIC	Panel 1				Panel 2 (Removable)		
	Type	Test Sheet Material	Installation (kN)	Pushout (N)	Max. First on Snap Force (N)	Min. First off Snap Force (N)	Min. 15th off Snap Force (N)
	SSA	Aluminum	6.7	880	58	13	4
	SSS	Aluminum	6.7	880	89	27	9
	SSS	Cold-rolled Steel	15.5	1780	89	27	9
	SSC	Cold-rolled Steel	16	1780	89	27	9
	KSSB	FR-4 Fiberglass	2.2	484	58	13	4

(1) The installation and pushout values reported are averages when all installation specifications and procedures are followed. Variations in mounting hole size, panel material and installation procedure will affect this data. Performance testing of this product in your application is recommended. We will be happy to provide samples for this purpose.

RoHS compliance information can be found on our website.

Specifications subject to change without notice. Check our website for the most current version of this bulletin.

PennEngineering®



North America: Danboro, PA 18916 USA • E-mail: info@pemnet.com • Tel: +1-215-766-8853 • Fax: +1-215-766-0143 • 800-237-4736 (USA Only)
U.K. And Europe: Doncaster, England • E-mail: uk@pemnet.com Tel: +44 (0)1302 765700 • Fax: +44 (0)1302 367580
Asia/Pacific: Singapore • E-mail: singapore@pemnet.com • Tel: +65-6-745-0660 • Fax: +65-6-745-2400
 Shanghai, China • E-mail: china@pemnet.com • Tel: +86-21-5868-3688 • Fax: +86-21-5868-3988

Visit our PEMNET™ Resource Center at www.pemnet.com

CAGE-46384